

## Nirmal Automation

### Retractable Aluminum Panel Bioclimatic Pergola New Generation Open Air Culture

Nirmal Automation uses automatic smart panels that allow you to adjust the shading of your outdoor spaces. The panels provide protection from direct sunlight with the option of opening partially or fully. The synchronized aluminum panels retract up to 80% to provide a clear view of the sky. The simultaneous movement of the panels allows for a smooth roof opening and can be paused at any point to provide the desired amount of ventilation. When opened, Nirmal Automation regulates the natural temperature and when fully closed creates a closed, water-resistant environment. It creates a comfortable outdoor area that you can enjoy on sunny or rainy days. It is resistant to heavy snow loads and strong winds. Its special design ensures ease of assembly and quick installation. Thanks to the use of aluminum and stainless steel, it becomes a permanent pergola that you can enjoy for many years. Nirmal Automation can be closed from all sides with N-Zipscreen to create a cooling effect in summer or equipped with glass panels to enjoy the view in winter. It is the ideal choice for terraces. It is suitable for use in residential buildings or commercial spaces such as hotels and restaurants. Tests have been carried out at international standards to demonstrate the excellent performance of our pergolas against the most adverse weather conditions.

- **Wind Load:** Standard EN 13659 class 6 (avg. 112 km/h). Any breakage detected
- **Snow Load:** Standard EN-1999 EUROCODE 9 (art. 100 kg/m<sup>2</sup>, including its own weight) aluminum structures project.
- **Rain Load:** Standard EN 12056 (0.03 l/s max.) steady heavy rain approx. 108 l.m<sup>2</sup>/h.
- **Rainwater Drainage:** Water is transferred to the channel profiles from special grooves on the aluminum lamella profiles. Then, it is transferred to the vertical carrier feet and discharged. is done. Security Concealed drains and power lines.
- **Surface:** Qualicoat, Qualideco certified. RAL painted, wood patterned products. It has a 10-year warranty.

## TECHNICAL DETAILS

### TECHNICAL DETAILS

- Slat measures 299 mm x 56 mm.
- Maximum lamella length 4000 mm.
- The lamellae can be retracted up to 80%.
- Material/6063 T5 aluminum, stainless steel.
- All colors you choose can be applied according to the RAL color standard.
- Motorized system and remote control.
- Great resistance to rainy weather conditions, snow water and wind
- Blade dimensions 299 mm x 56 mm.
- Max blade length 4000 mm.
- Blades can retract up to 80%.
- Materials/6063 T5 aluminum, stainless steel.
- Coloring of your choice, according to the RAL color standard.
- Capability of electrical motion and remote control
- Great resistance to weather conditions of rain, snow humidity and wind

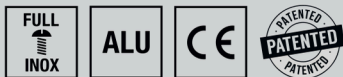
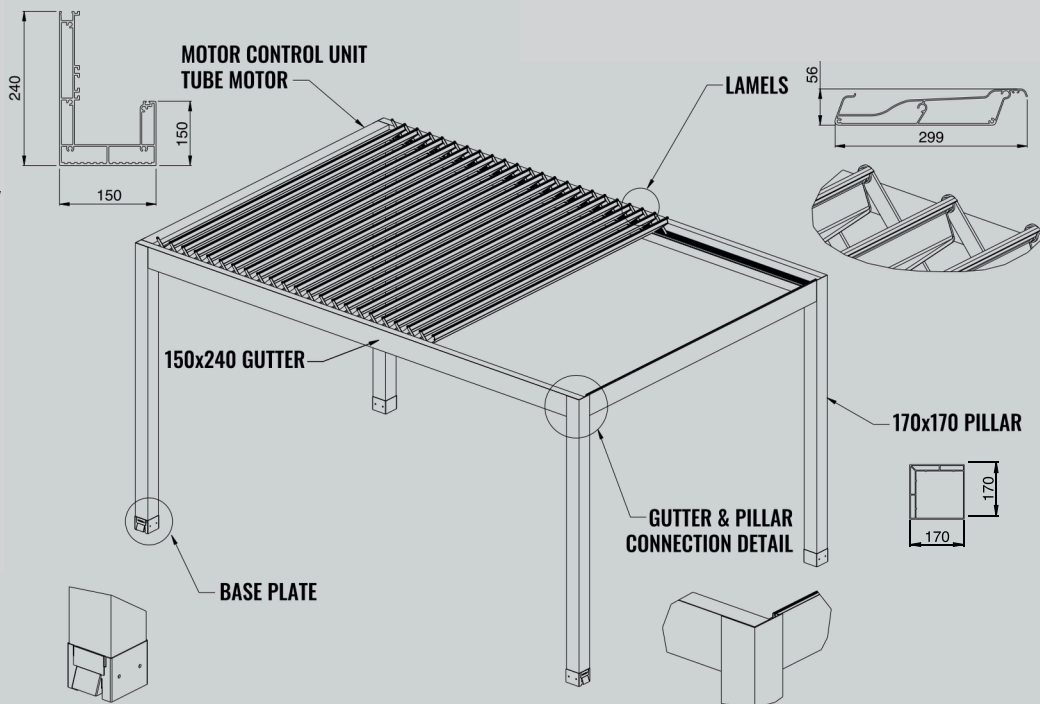

## Nirmal Automation

### Benefits of Retractable Aluminum Panel Bioclimatic Pergola New Generation Open Air Culture

#### 1. Adjustable Sunlight & Shade:

Louvers can be tilted to control the amount of sunlight entering the space. Provides shade on hot days and allows sunlight in cooler weather.

#### 2. Weather Protection:

Fully closed louvers provide shelter from rain, keeping outdoor areas dry. Reduces wind exposure when partially closed.

#### 3. Ventilation & Temperature Control:

Open louvers allow heat to escape, keeping the area cooler in summer. Creates natural airflow, reducing the need for fans or air conditioning.

#### 4. Energy Efficiency:

Reduces indoor cooling costs by blocking excess heat. Enhances natural light use, reducing electricity consumption.

#### 5. Modern Aesthetic & Increased Property Value:

Adds a sleek, contemporary look to homes, patios, and commercial spaces.

Increases the value of a property by enhancing outdoor usability.

#### 6. Smart Automation & Convenience:

Can be controlled via remote, app, or smart home systems. Some models have rain sensors that automatically close when it starts raining.

#### 7. Extended Outdoor Living & Entertainment Space:

Transforms patios and decks into year-round usable spaces. Ideal for outdoor dining, social gatherings, and relaxation.

#### 8. Low Maintenance & Durability:

Made from materials like aluminum, which resist rust and corrosion. Requires minimal cleaning and maintenance.

#### 9. Customization Options:

Available in different colors, finishes, and sizes to match various designs. Can include integrated lighting, fans, and heating elements.

#### 10. UV Protection & Furniture Longevity

Blocks harmful UV rays, preventing fading of outdoor furniture and flooring.



## Our esteemed client list includes

Automobile	Construction	IT Sector	Pharma And Foods	Hotels, Malls, Entertainment	Others
Tata Motor	Rohan	Infosys	Tetra Park	J W Mariott	Sandvik Asia
Bajaj	Ashoka Buildcon	AXA	Nestle	IBIS Hotels	KSB
Mahindra & Mahindra	Devi Construction	Eon IBT Free Zone	Chitale Bandhu	Novotel	Hindalco
Mercedes Benz	Gera Developers	KPIT Cummins	Coca Cola	Reliance Fresh	Kirloskar Brothers
Volkswagan	Ratilal Bhagwandas	Cybage	Corning India	Hotel Ambience	United Cranes
Skoda Auto	Elite Builders	ANSYS	Cipla	Ranka Jewllers	Oriental Rubber
Replus	Panchshil	PTC	Rich Graviss	Hotel New Leaf	Suzion
Flash Electronics	Vascon	Aurion ProSena	Oriental Yeast	Westend Mall	Kirloskar Pneumtaic
Volvo And Eicher	Shimzu Corporation	Expo India	Centaur Pharma	Aeromall	Techera
Harmon	Amanora Park	Magarpatta	Dream Plast	Velankani	Seco Tools
Bridestones	Coproration Shimzu	Panchshil	B G Chitale Dairy	Solaris	Bobst India
Bosch	Nyati Group	Birla Soft	Cherry Park		Lifeline Hospitle
SKF	Magarpatta Township	Blue Ridge	Serum Institue		Mahaver Metal
Honeywell Turbo	L&W Construction		PV Son's		Harnex Systems
Piggio	Malpani		Datwyler		Pathera Graphite
Star Engineers	Goel Ganga		Alfa Laval		
GE Stamp	Suroj Buildcon		Drytech		
Motherson	Ulka Projects		Bharat Rubber		
Pinacal Mobility	Bhate Rajee		Tulip Pharma		
Super Auto	Ratnarup		Tastey Bite		
Eka Mobility	Kakkad Construction		Pravin Masale		

## Who can benefit from our Retractable Aluminum Panel Bioclimatic Pergola



**Warehouses & Distribution Centers**



**Manufacturing Plants**



**Cleanrooms & Laboratories**



**Any Business with a Loading Dock**



**Hospitals & Healthcare Facilities**



**Airports & Transportation Hubs**



**Cold Storage & Freezer Rooms**



**Food & Beverage Industry**



## OTHER PRODUCT



AUTOMATIC  
SLIDING DOOR



HIGH SPEED  
DOOR



SECTIONAL  
DOOR



ROLLING  
SHUTTER



SWING  
DOOR



GARAGE  
DOOR



DOCK  
LEVELER



BOLLARD



SLIDING  
GATE



SWING  
GATE



RETRACTABLE  
GATE



BOOM  
BARRIER

### For Enquiries

(+91) 77740 83386

Mail: [sales@nirmalautomation.com](mailto:sales@nirmalautomation.com)

(+91) 77220 39370

Mail: [sales1@nirmalautomation.com](mailto:sales1@nirmalautomation.com)

(+91) 92254 35222

Mail: [marketing@nirmalautomation.com](mailto:marketing@nirmalautomation.com)

### For more details

visit: [www.nirmalautomation.com](http://www.nirmalautomation.com)

### Nirmal Automation Pvt. Ltd.

#### Corporate Office:

7, Vrindavan Garden Society,  
Opp Jit Ground, Lokmanya Colony,  
off Paud Road, Kothrud.  
Pune- 411038, Maharashtra, India.

### Follows Us:

