

Güneş ışıklarından korur.  
Protection from the sun.

Doğal havalandırma sağlar.  
Natural ventilation.

Isı kontrolü sağlar.  
Adjusting of temperature.

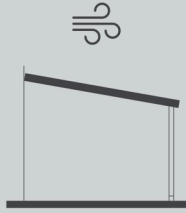

Rüzgara karşı dirençlidir.  
Stability in wind.



Yağmura karşı koruma ve suyun tahliyesini sağlar.  
Protection from rain, excess water drainage.

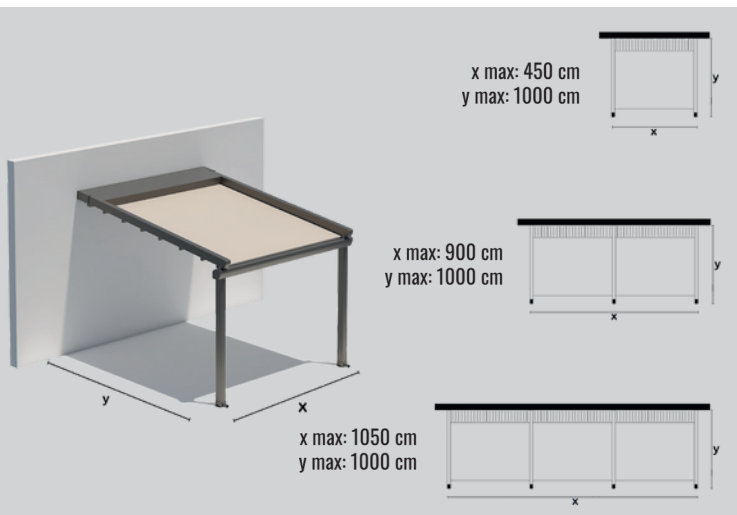

x max: 450 cm  
y max: 1000 cm

x max: 900 cm  
y max: 1000 cm

x max: 1050 cm  
y max: 1000 cm

## Nirmal Automation

Retractable PVC Fabric Motorized Pergola

Original Pergola Design

Nirmal Automation offers you a stylish and modern pergola for outdoor spaces. It is a pergola system created for those who want to experience the balanced harmony of classic lines, durable materials and quality design. It is made entirely of aluminum and stainless steel, maintenance-free. It is a retractable pergola awning system designed for outdoor use, which aims to create a comfortable, permanent area and protect users from sun, rain and wind. In addition, specially designed aluminum frames integrated into the structure provide durability with silent and pleasant performance. The system, which provides high protection against sun, rain and wind thanks to its special sunshade fabric, allows you to make the most of outdoor spaces such as gardens, balconies, verandas and terraces. Pergola Alu's shading system can be integrated with various closing systems, as well as a completely closed area can be created.

1. Rail beam is a patented monoblock system in the Avantgarde series. Rail section internal feders are specially designed horizontally and vertically and reinforced with federters due to snow load. Single rail and double curtain solution has been made more practical with the Avantgarde series.
2. lives and farms. rainfall, EN LED downlight modules optionally integrated in desired numbers onto the fabric holder profiles on the motion ceiling cover.
3. The carrier cars in the system are made of aluminum body, INOX pin and 4 wheels, our other mobile cars are made of plastic body resistant to the external environment, it consists of INOX Pin and 4 wheels.
4. The ceiling cover material used in the system is a PVC based 800gr/m<sup>2</sup> grammage (EN ISO 2286-2), three layer, Blackout (impermeable), waterproof, non-flammable, flame retardant (CL2-U NI EN 13773) properties, pre-tensioned, patented fabric. The fabric is from Sorge Ferrari and Sattler and its colorfastness guarantee is 10 years.
5. The opening/closing movement of the ceiling cover is done by a remote control motor. The motor using the internal receiver is Somfy brand and is under 5-year warranty.
6. T10 polyurethane timing belt system, which can be specially adjusted, is used for tensioning the system.
7. Rail profiles used in the system are Müminyum EN AW 6060-166 scrisi, connection parts are INOX.
8. All surfaces are painted with Qualicoat certified paint.
9. Since the Doro design does not have a double wall, the system is suitable for closing the lower frames with glass.

# TECHNICAL DETAILS

## TECHNICAL DETAILS

- Ray Profile: 135x160mm.
- You Profile: 135x170mm.
- Foot Profile: 135x135mm.
- Material/6063 T5 aluminum, stainless steel.
- All colours you choose can be applied according to the RAL colour standard.
- Motorized system and remote control.
- Great resistance to rainy weather conditions, snow water and wind.
- Runner Profile: 135x160 mm. Gutter Profile: 135x170 mm.
- Pillar Profile: 135x135 mm.
- Materials/6063 T5 aluminum, stainless steel.
- Coloring of your choice, according to the RAL color standard.
- Capability of electrical motion and remote control.
- Great resistance to weather conditions of rain, snow humidity and wind.

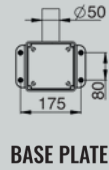
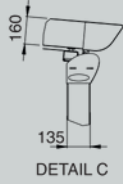
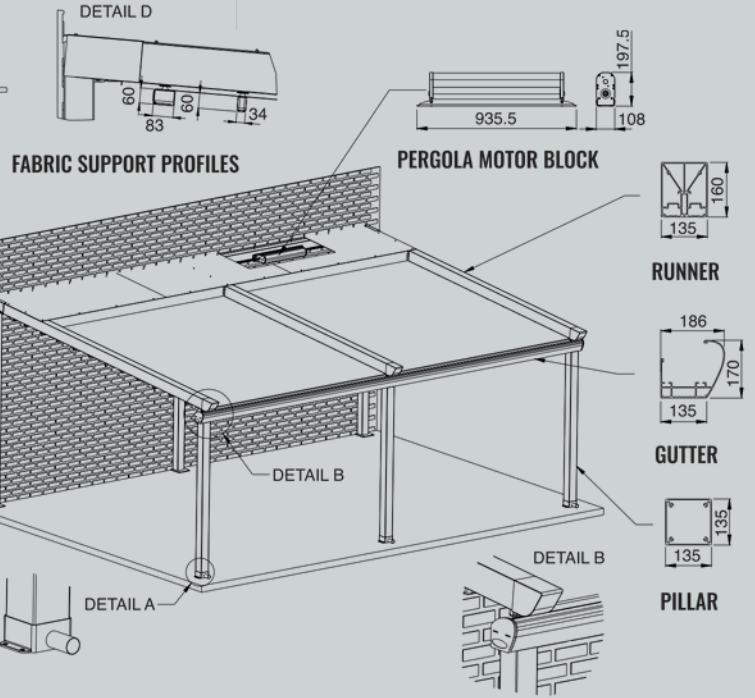
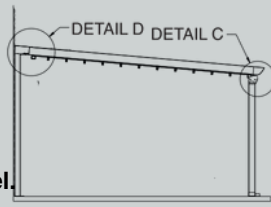
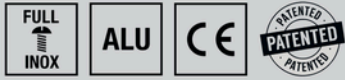

## Key Benefits of an Automatic Retractable Roof

**Weather Adaptability & Comfort** – Easily open or close depending on the weather, ensuring year-round comfort.

**Convenience & Automation** – Operate effortlessly via remote, smartphone, or weather sensors for hands-free control.

**Energy Efficiency** – Enhances natural ventilation, reduces air conditioning needs, and lowers energy bills.

**Aesthetic Appeal & Property Value** – Adds a modern touch to homes, restaurants, and commercial spaces while increasing property value.

**Versatility & Usability** – Perfect for patios, pools, stadiums, and event spaces, extending their functionality in all seasons.

**Durability & Protection** – Shields against harsh sunlight, rain, and snow, while protecting furniture and interiors from UV damage.

**Smart Technology Integration** – Compatible with home automation systems, voice commands, and weather-responsive sensors.

**Better Airflow & Natural Light** – Promotes fresh air circulation and maximizes daylight, reducing artificial lighting needs.



## Our esteemed client list includes

Automobile	Construction	IT Sector	Pharma And Foods	Hotels, Malls, Entertainment	Others
Tata Motor	Rohan	Infosys	Tetra Park	J W Mariott	Sandvik Asia
Bajaj	Ashoka Buildcon	AXA	Nestle	IBIS Hotels	KSB
Mahindra & Mahindra	Devi Construction	Eon IBT Free Zone	Chitale Bandhu	Novotel	Hindalco
Mercedes Benz	Gera Developers	KPIT Cummins	Coca Cola	Reliance Fresh	Kirloskar Brothers
Volkswagan	Ratilal Bhagwandas	Cybage	Corning India	Hotel Ambience	United Cranes
Skoda Auto	Elite Builders	ANSYS	Cipla	Ranka Jewllers	Oriental Rubber
Replus	Panchshil	PTC	Rich Graviss	Hotel New Leaf	Suzion
Flash Electronics	Vascon	Aurion ProSena	Oriental Yeast	Westend Mall	Kirloskar Pneumtaic
Volvo And Eicher	Shimzu Corporation	Expo India	Centaur Pharma	Aeromall	Techera
Harmon	Amanora Park	Magarpatta	Dream Plast	Velankani	Seco Tools
Bridestones	Coproration Shimzu	Panchshil	B G Chitale Dairy	Solaris	Bobst India
Bosch	Nyati Group	Birla Soft	Cherry Park		Lifeline Hospitle
SKF	Magarpatta Township	Blue Ridge	Serum Institue		Mahaver Metal
Honeywell Turbo	L&W Construction		PV Son's		Harnex Systems
Piggio	Malpani		Datwyler		Pathera Graphite
Star Engineers	Goel Ganga		Alfa Laval		
GE Stamp	Suroj Buildcon		Drytech		
Motherson	Ulka Projects		Bharat Rubber		
Pinacal Mobility	Bhate Rajee		Tulip Pharma		
Super Auto	Ratnarup		Tastey Bite		
Eka Mobility	Kakkad Construction		Pravin Masale		

## Who can benefit from our Retractable PVC Fabric Motorized Pergola



**Warehouses & Distribution Centers**



**Manufacturing Plants**



**Cleanrooms & Laboratories**



**Any Business with a Loading Dock**



**Hospitals & Healthcare Facilities**



**Airports & Transportation Hubs**



**Cold Storage & Freezer Rooms**



**Food & Beverage Industry**



## OTHER PRODUCT



AUTOMATIC  
SLIDING DOOR



HIGH SPEED  
DOOR



SECTIONAL  
DOOR



ROLLING  
SHUTTER



SWING  
DOOR



GARAGE  
DOOR



DOCK  
LEVELER



BOLLARD



SLIDING  
GATE



SWING  
GATE



RETRACTABLE  
GATE



BOOM  
BARRIER

### For Enquiries

(+91) 77740 83386

Mail: [sales@nirmalautomation.com](mailto:sales@nirmalautomation.com)

(+91) 77220 39370

Mail: [sales1@nirmalautomation.com](mailto:sales1@nirmalautomation.com)

(+91) 92254 35222

Mail: [marketing@nirmalautomation.com](mailto:marketing@nirmalautomation.com)

### For more details

visit: [www.nirmalautomation.com](http://www.nirmalautomation.com)

### Nirmal Automation Pvt. Ltd.

#### Corporate Office:

7, Vrindavan Garden Society,  
Opp Jit Ground, Lokmanya Colony,  
off Paud Road, Kothrud.  
Pune- 411038, Maharashtra, India.

### Follows Us:

