



[www.nirmalautomation.com](http://www.nirmalautomation.com)

# SUMMARY



**Le Mans** - *Classic*

..... P 9



**Valance** - *Decorative Strip Profiles*

..... P 15

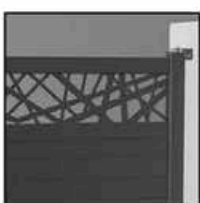

**Leyon** - *Laser Cut*

..... P 19



**Lecco** - *Alunox Decorations*

..... P 27



**Bianco** - *Duel Tone*

..... P 33



**Como** - *Louvered Profiles*

..... P 37



**ALU Fence**

..... P 40



**ALU Screen**

..... P 46

# Why ALU GATE

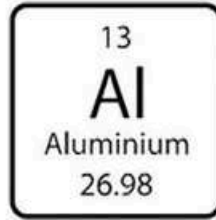

**100%  
Aluminium**



**Made In  
India**



**5 Years  
Warranty**



**No Weld,  
Fully Assembled**



**Rust  
Proof**



**Light  
Weight**



**Customized  
Size**



**Exterior Quality  
Powdercoat**



**Choice of  
Colours**



**Easy  
Assembly**



**Motorizable**



**100% Recyclable**

## 100 % ALUMINIUM

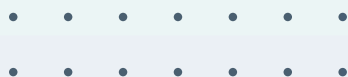

We use 100% aluminium for the entire structure of the gate.

Aluminium is light but same time strong, rigid and durable with its high strength to weight ratio .We use exclusively designed, reinforced profiles which are from 2 -3 mm thickness.

Aluminium is one of the metal which is resistant to corrosion. Aluminium does not rust over time .Hence aluminium gates will have a long life compared to wood or steel.

Aluminum is one of the most environmentally friendly material which is easily recyclable and ecological.

## No Weld, Fully Assembled

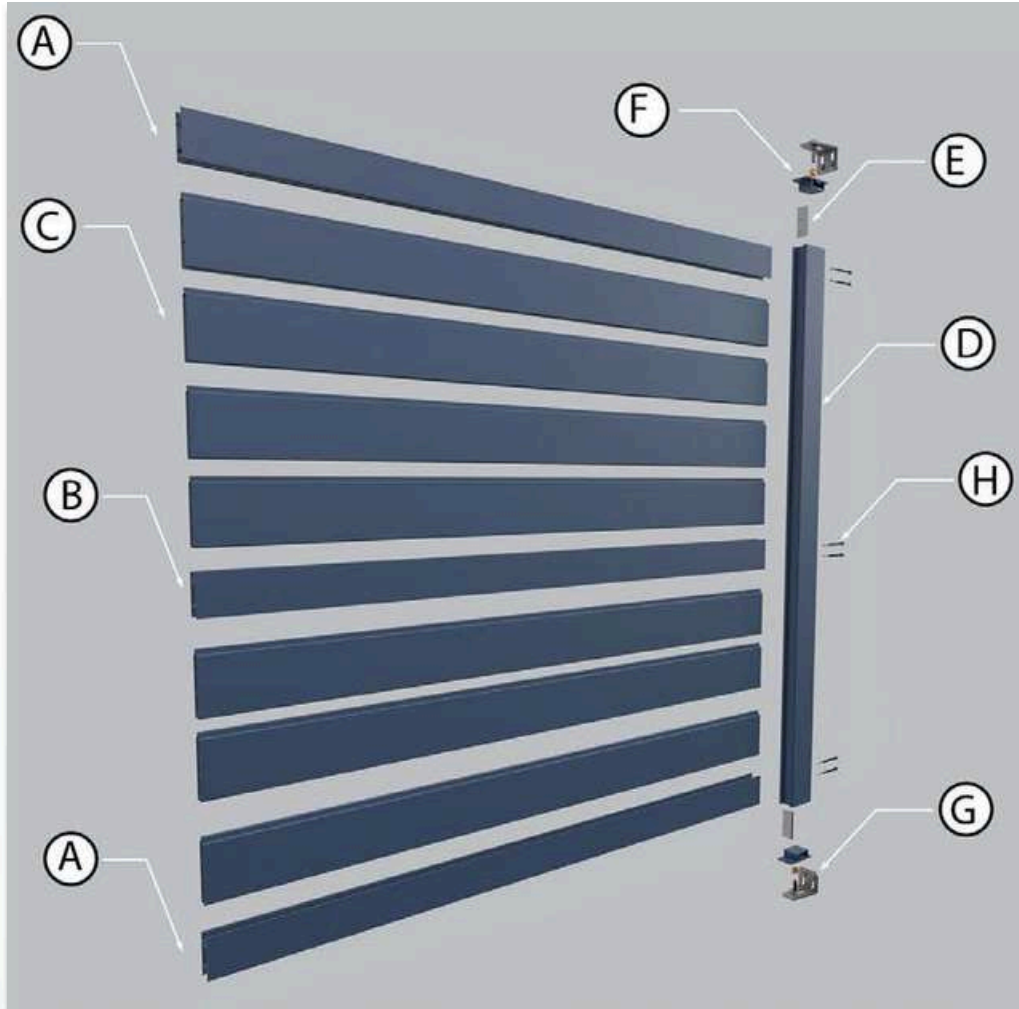

- •
- •
- •
- •
- •
- •

- • (A) Horizontal 85x32x2 mm
- • (B) Intermediate Horizontal 85x32x2 mm
- • (C) Infill 120x22x1.5 mm
- • (D) Vertical 96x50x2 mm
- • (E) Reinforcement Bar
- • (F) Aluminium Cap
- • (G) Pivot Hinge
- • (H) Stainless Steel Screw

We use the interlocking assembly system. Means, specially designed reinforced profiles are mechanically assembled by mortise and tenon joint method. This provides perfect rigidity and seamless aesthetics compared to a welded gate. All fixing screws are corrosion resistant stainless steel.

Our gates are made-to-measure and are assembled by hand and with great precision by qualified workers. At each stage, quality control is carried out to guarantee you a product of excellence.



## In House Powder Coating

Our own powder coating plant enables total control on the quality, treatment and allows us uniformity and a wide variety of colors and textures to choose from. AluGate has chosen exterior quality, powders from the world renowned brand JOTUN.

The process involves 3 stages. First, process of pre treatments where

profiles are dipped into series of tanks with different chemicals and water. Secondly spraying the aluminum profile with a layer of electrostatically charged powder and thirdly it is moved to the heating oven where powder melts and stick together into rigid and durable structure.



Thanks to this process, the surface of the aluminum profiles acquires optimal properties of resistance to the most severe environmental conditions.



## Choice of Colours





# Swing Gate Accessories

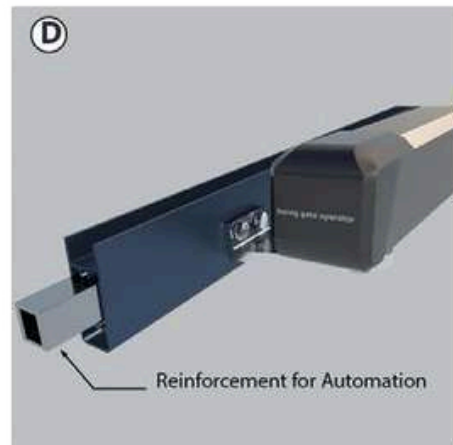
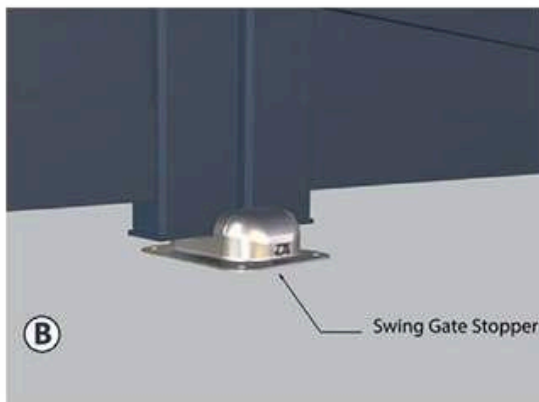
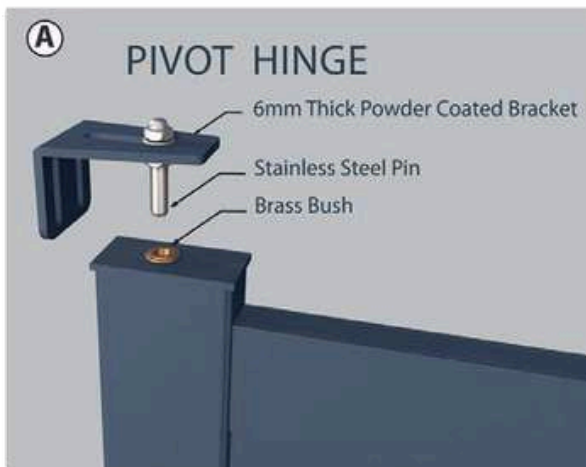
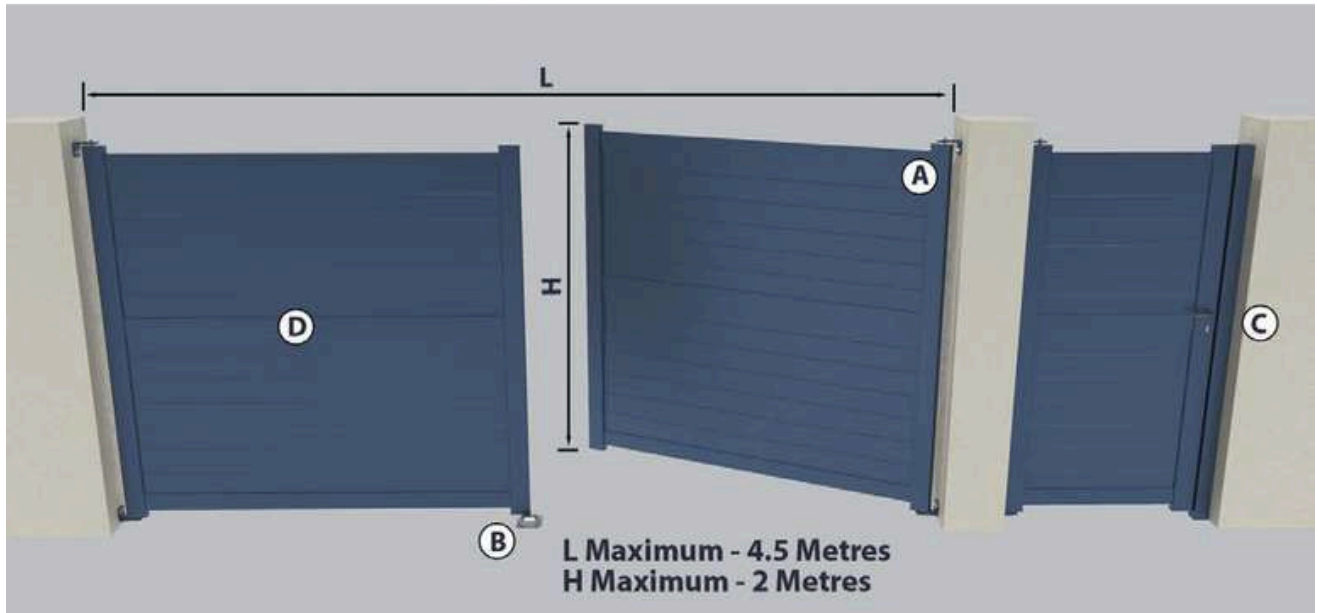



# Sliding Gate Accessories

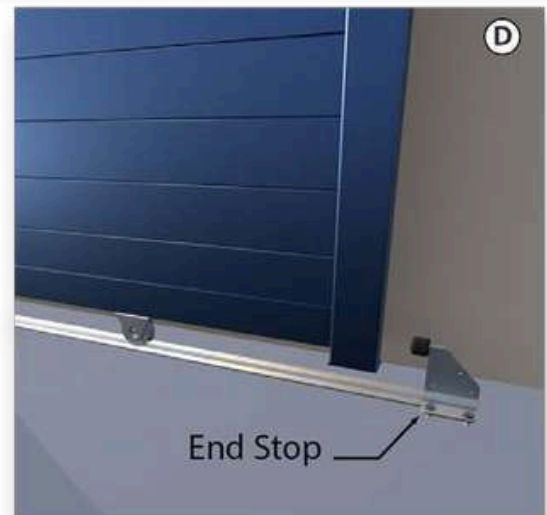
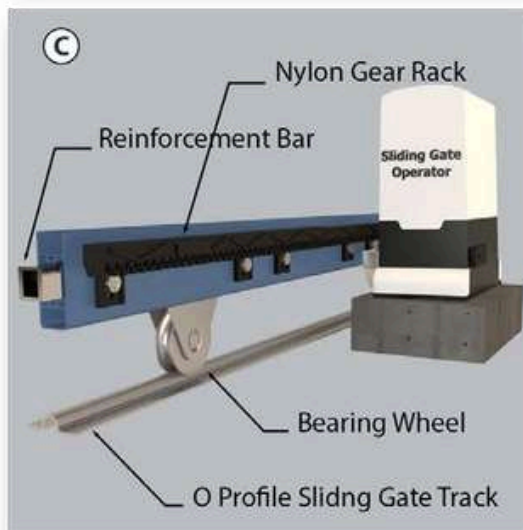
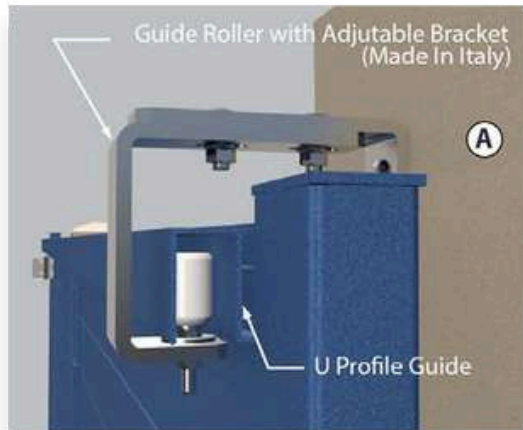
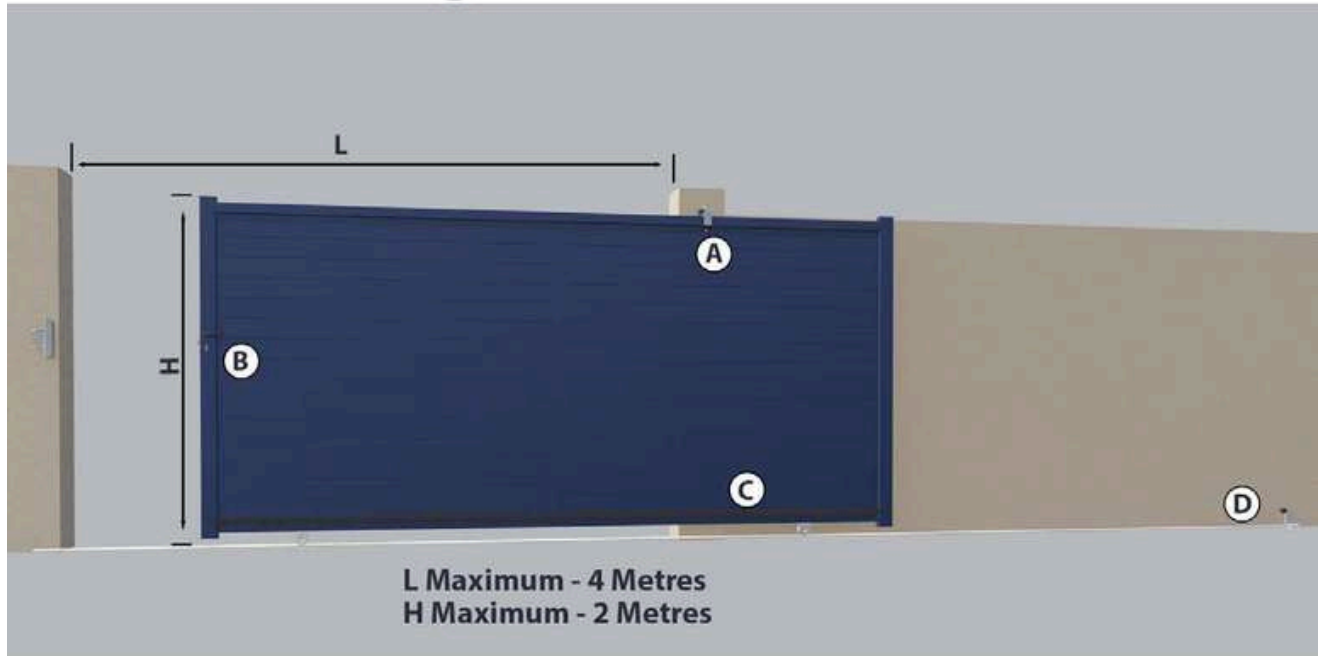







**LE MANS SWING GATE**  
Collection



**LE MANS 03**  
Swing Gate  
Soil Grey +  
Metalic White  
Aluminium



**LE MANS 04**  
Swing Gate  
Wine Red





**LE MANS SWING GATE**  
Collection

**LE MANS 07**  
Swing Gate  
Sable Blue +  
Metalic White  
Aluminium



**LE MANS 08**  
Swing Gate  
Olive Green +  
Metalic White  
Aluminium







**VALENCE SWING GATE**  
Collection



**Decorative Aluminium Strip Profile**

Our specially designed 20 mm strip profiles, in anodized aluminium finish can be integrated between the infill panels in different patterns, which provides a premium impression to your aluminium gate.



**VALENCE 01**  
Swing Gate  
Sable Blue+  
Anodized  
Aluminium Strip





**VALENCE SLIDING GATE**  
Collection

**VALENCE 04**  
Sliding Gate  
Wine Red +  
Anodized  
Aluminium Strip



**VALENCE 05**  
Sliding Gate  
Soil Grey+  
Anodized  
Aluminium Strip







# LASER CUT

We offer a wide range of integrated laser cut decorations on 3 mm thick aluminium sheets to provide a personalised character to your gate. The choice of laser cut design and different incorporation styles makes your gate totally unique.

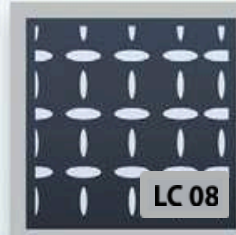
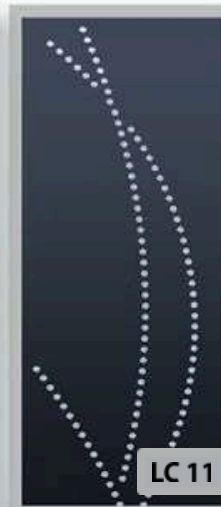
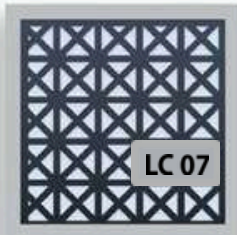
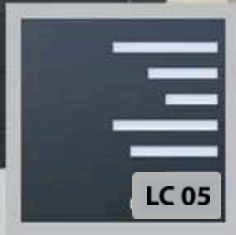



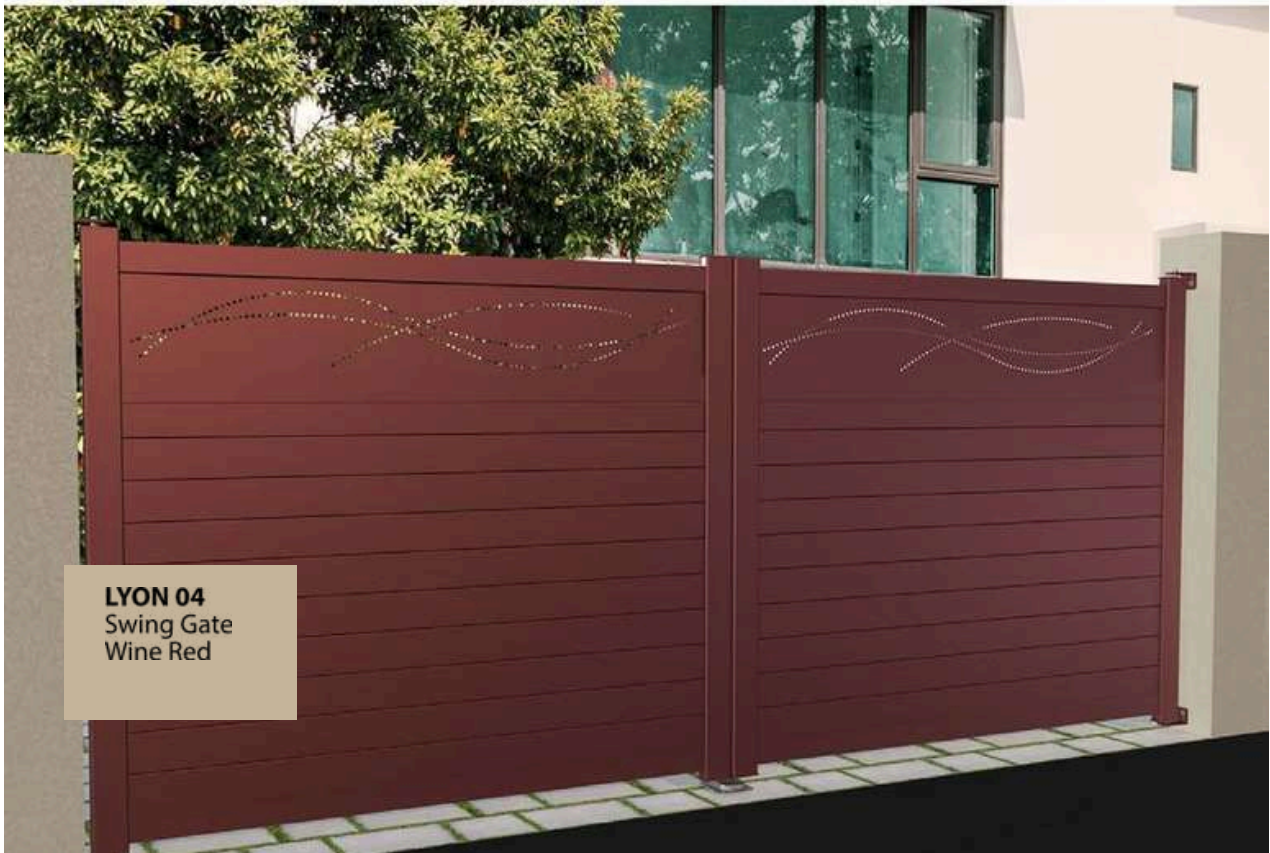
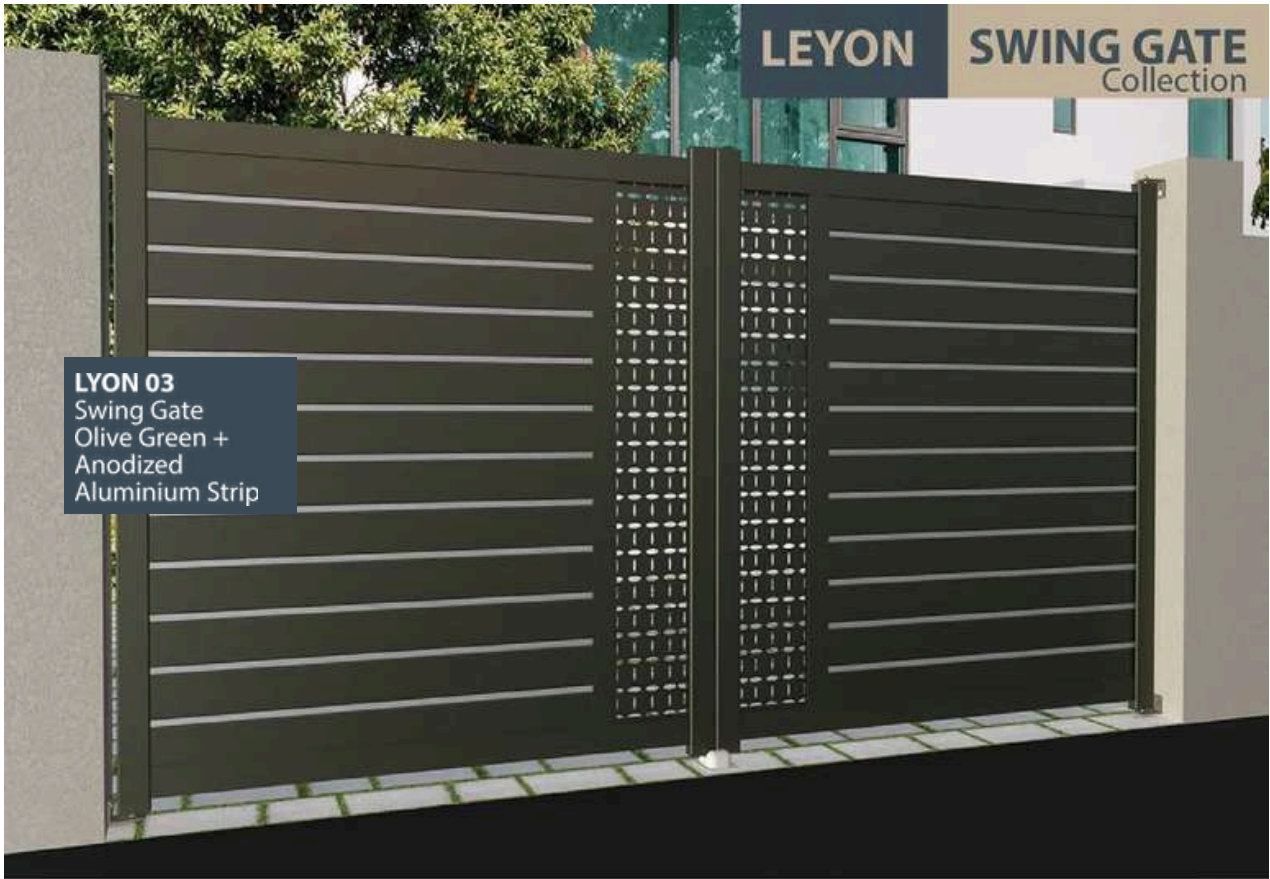













**LECCO**

**SWING GATE**  
Collection

# ALUNOX DECORATIONS

To personalize your gate with elegance ALUGATE offers you a range of anodised aluminum decorations in brushed finish. We offer different shapes and patterns which are fixed to the gate surface using special application adhesives.

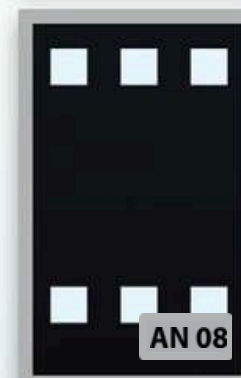
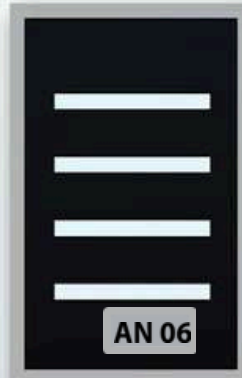





**NIRMAL**



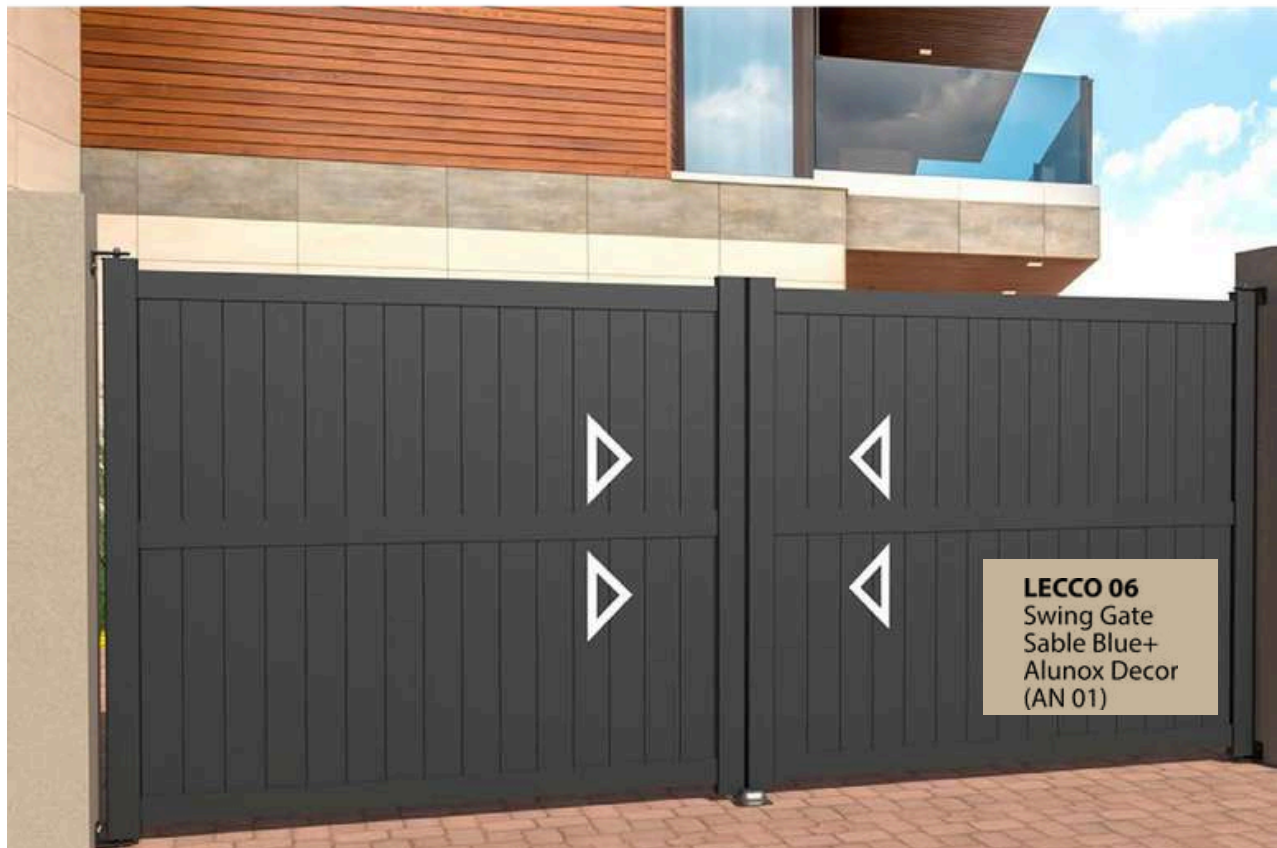

**LECCO**

**SLIDING GATE**  
Collection



**LECCO 07**  
Sliding Gate  
Soil Grey+  
Alunox Decor  
(AN 08)



**LECCO 08**  
Sliding Gate  
Wine Red+  
Alunox Decor  
(AN 05)







**BIANCO**

**SWING GATE**  
Collection

**BIANCO 03**  
Swing Gate  
Wine Red+  
Metalic White  
Aluminium



**BIANCO 04**  
Swing Gate  
Olive Green +  
Metalic White  
Aluminium







**BIANCO** SLIDING GATE  
Collection



**BIANCO 07**  
Sliding Gate  
Soil Grey+  
Metalic White  
Aluminium



**BIANCO 08**  
Sliding Gate  
Wine Red +  
Metalic White  
Aluminium

**COMO**

**SWING GATE**  
Collection



**LOUVER PROFILE**

Our specially designed LOUVER profile which enables passage of wind at the same time provide optimal privacy and premium aesthetics.



**COMO 01**  
Swing Gate  
Olive Green+  
Metalic White  
Aluminium

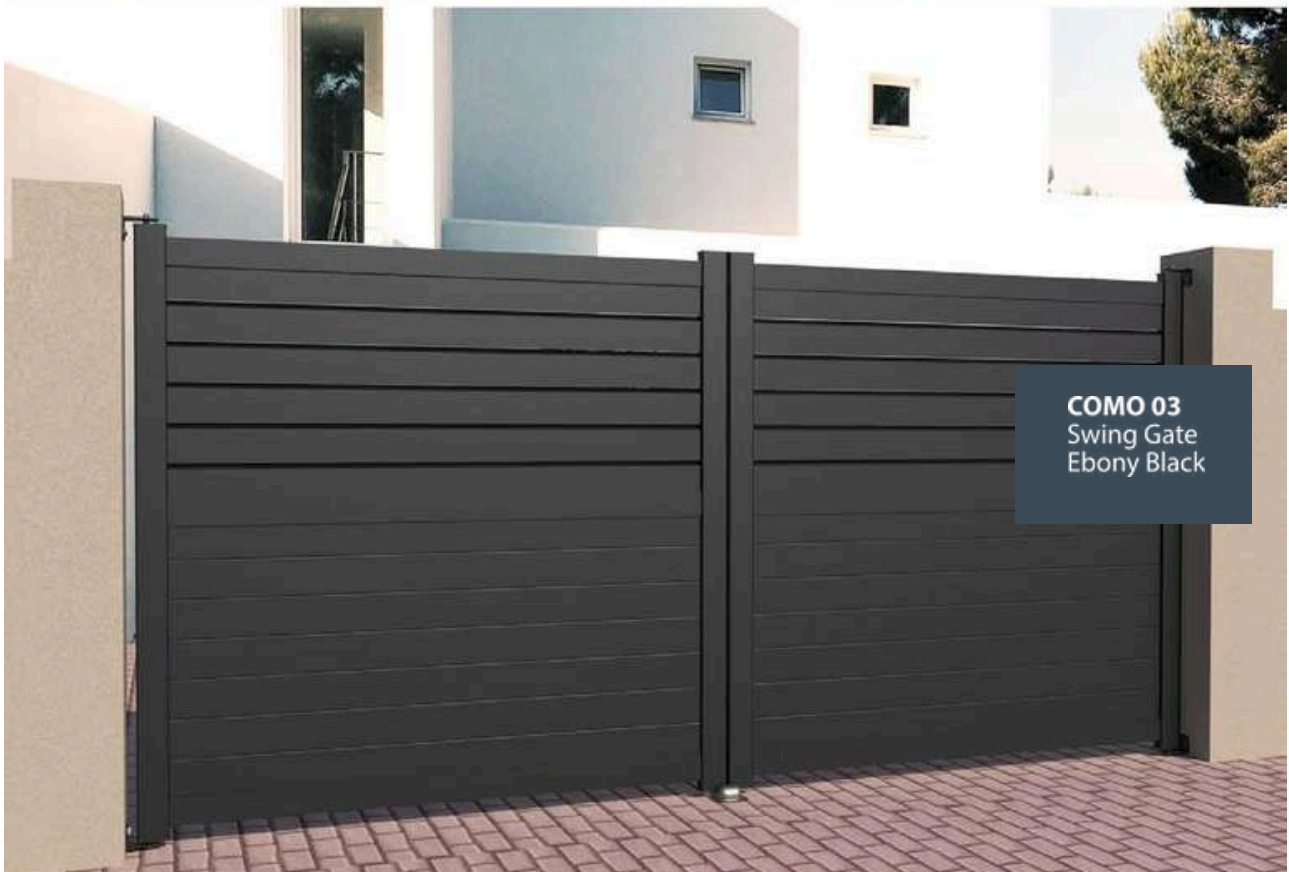



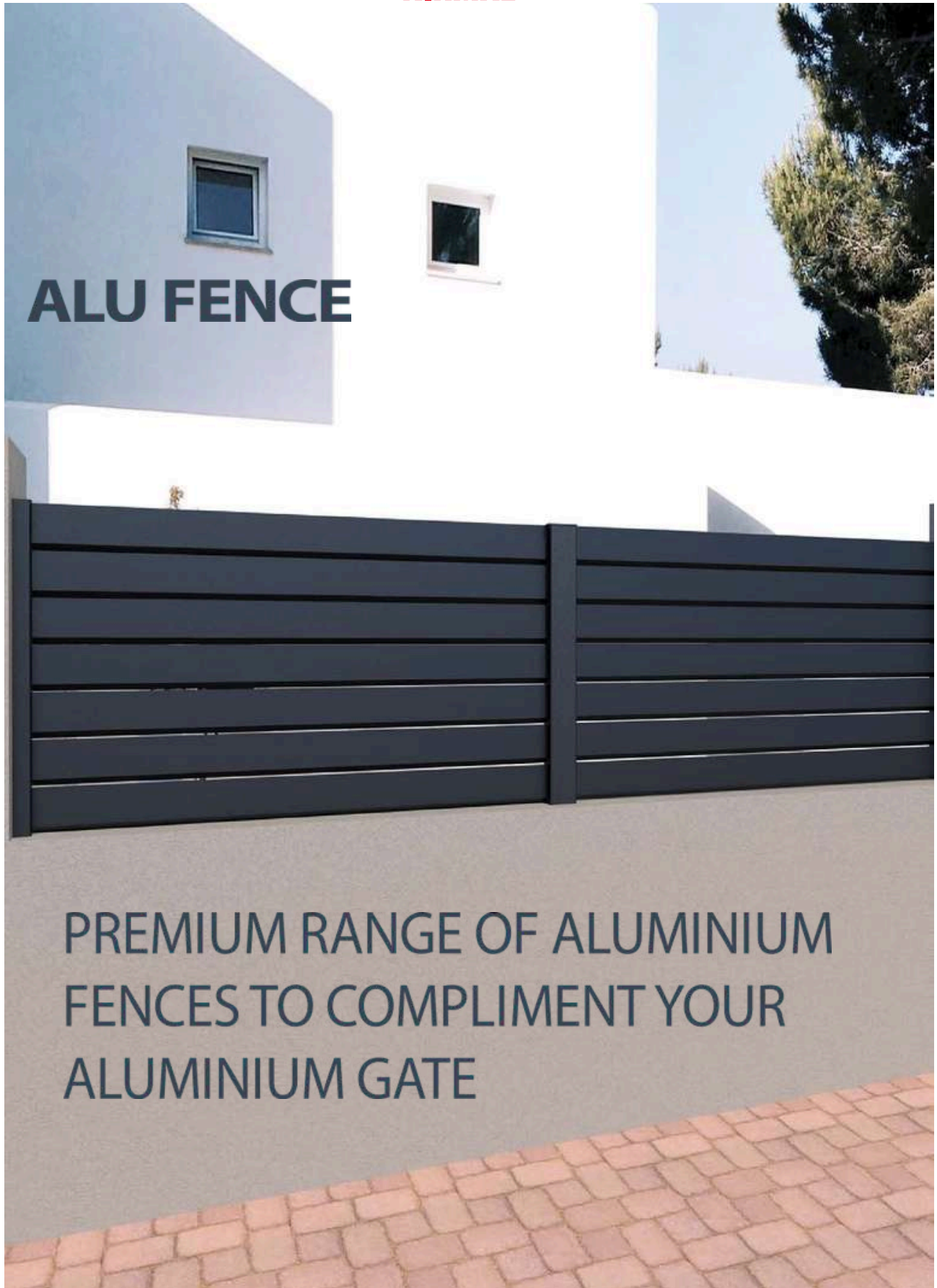

# ALU FENCE

PREMIUM RANGE OF ALUMINIUM  
FENCES TO COMPLIMENT YOUR  
ALUMINIUM GATE

## EASY TO ASSEMBLE MODULAR SYSTEM

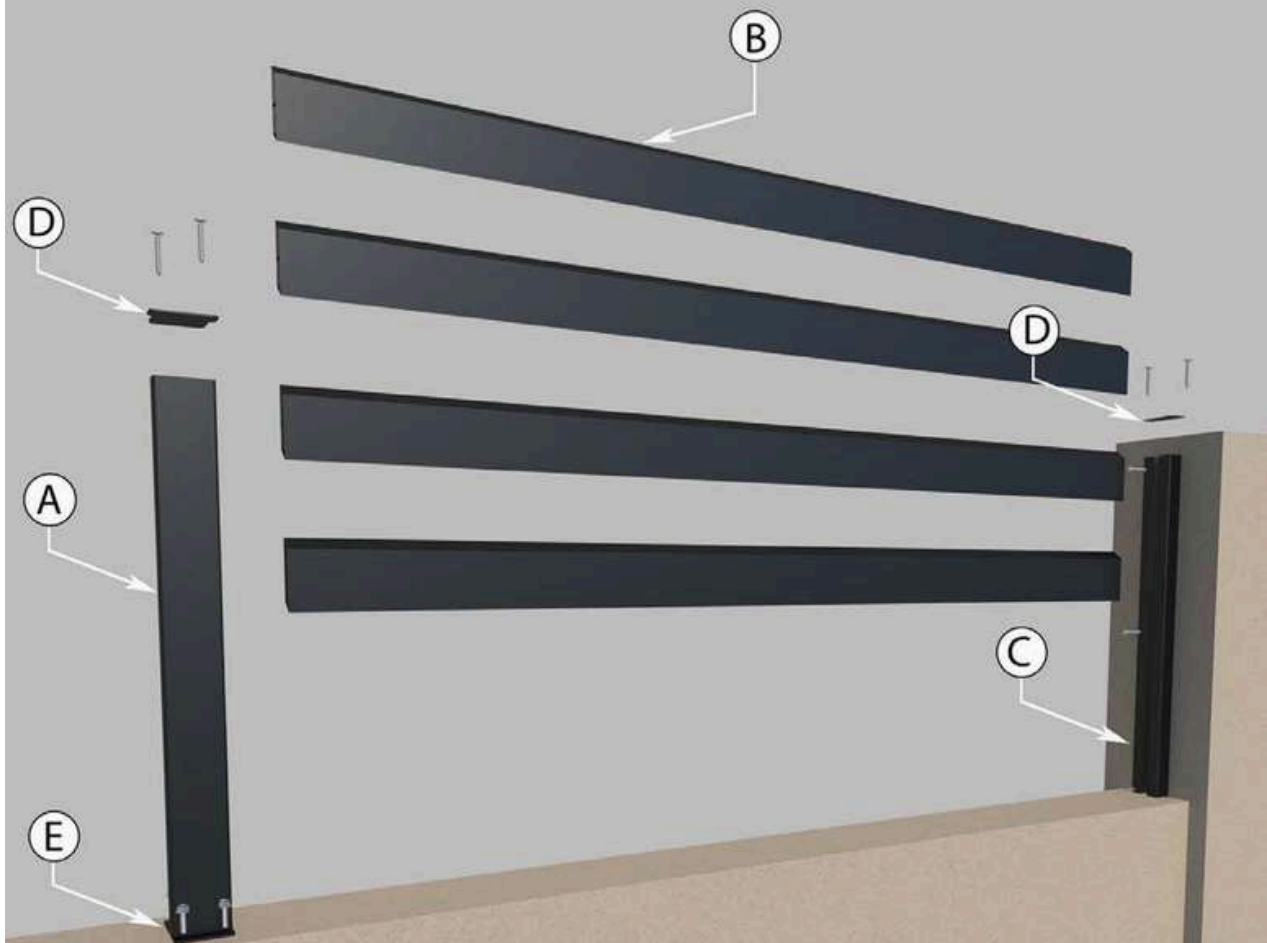

- (A) 2 way fence post (85x80mm)
- (B) Infil pannels (120x22mm)
- (C) 1 way fence post (80x38mm)
- (D) Cap for post
- (E) Base plate for post





# ADAPTABLE TO DIFFERENT SHAPES OF THE COMPOUND WALL

Steps of  
different  
heights



45 degree  
corner

90 degree  
corner



Round  
corner

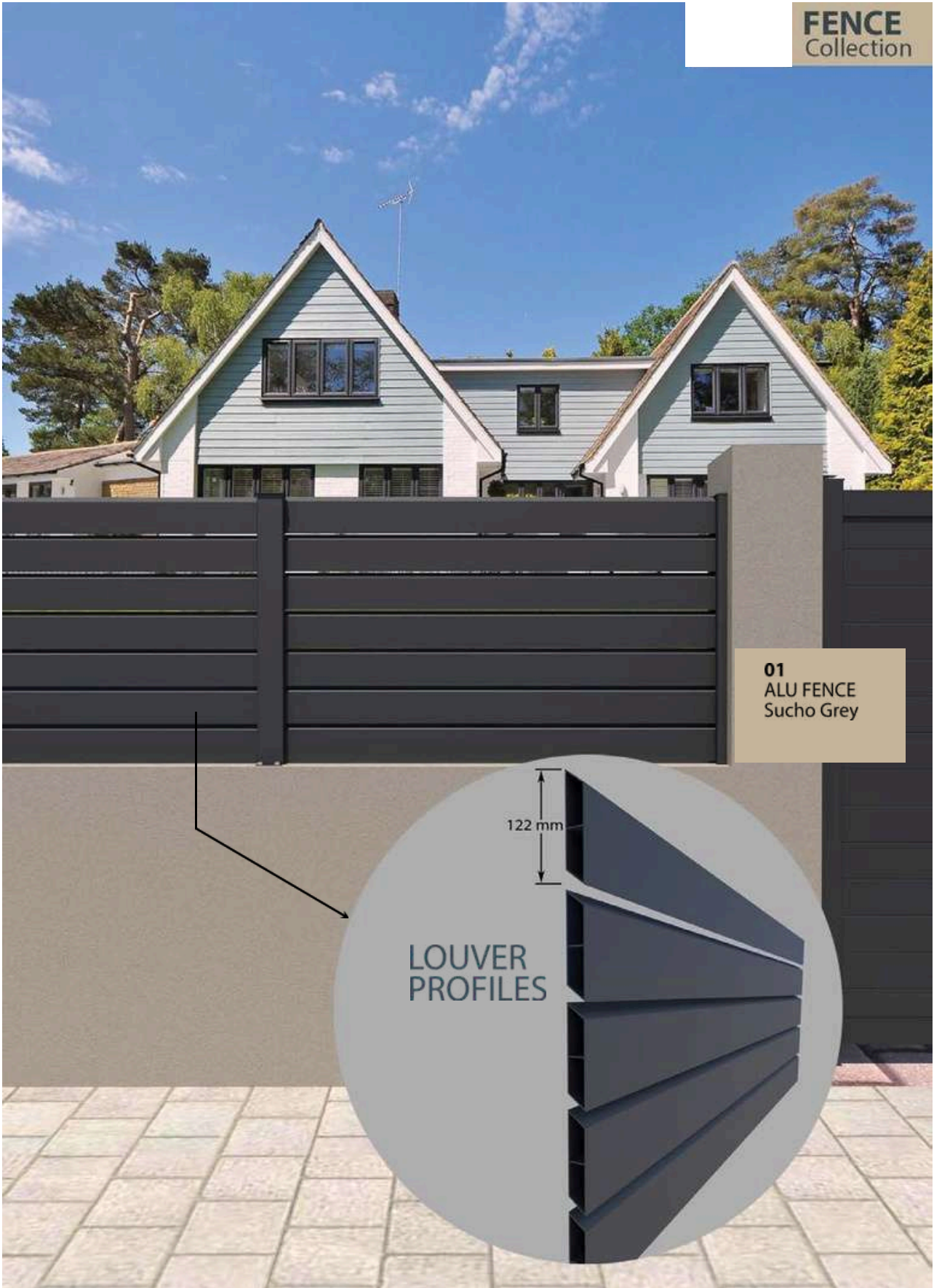

**01**  
ALU FENCE  
Sucho Grey



**FENCE**  
Collection



**02**  
ALU FENCE  
Soil Grey



**03**  
ALU FENCE  
Schuco Grey



**04**  
ALU FENCE  
Olive Green



**05**  
ALU FENCE  
Schuco Grey +  
Anodized  
Aluminium Strip

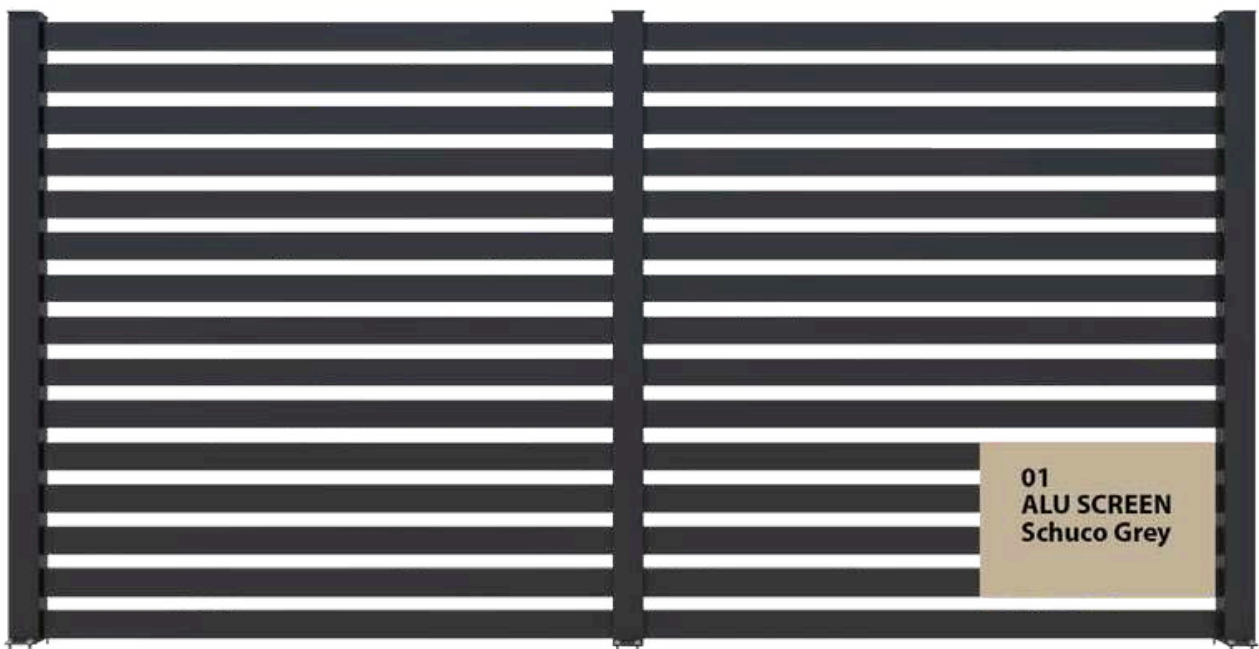
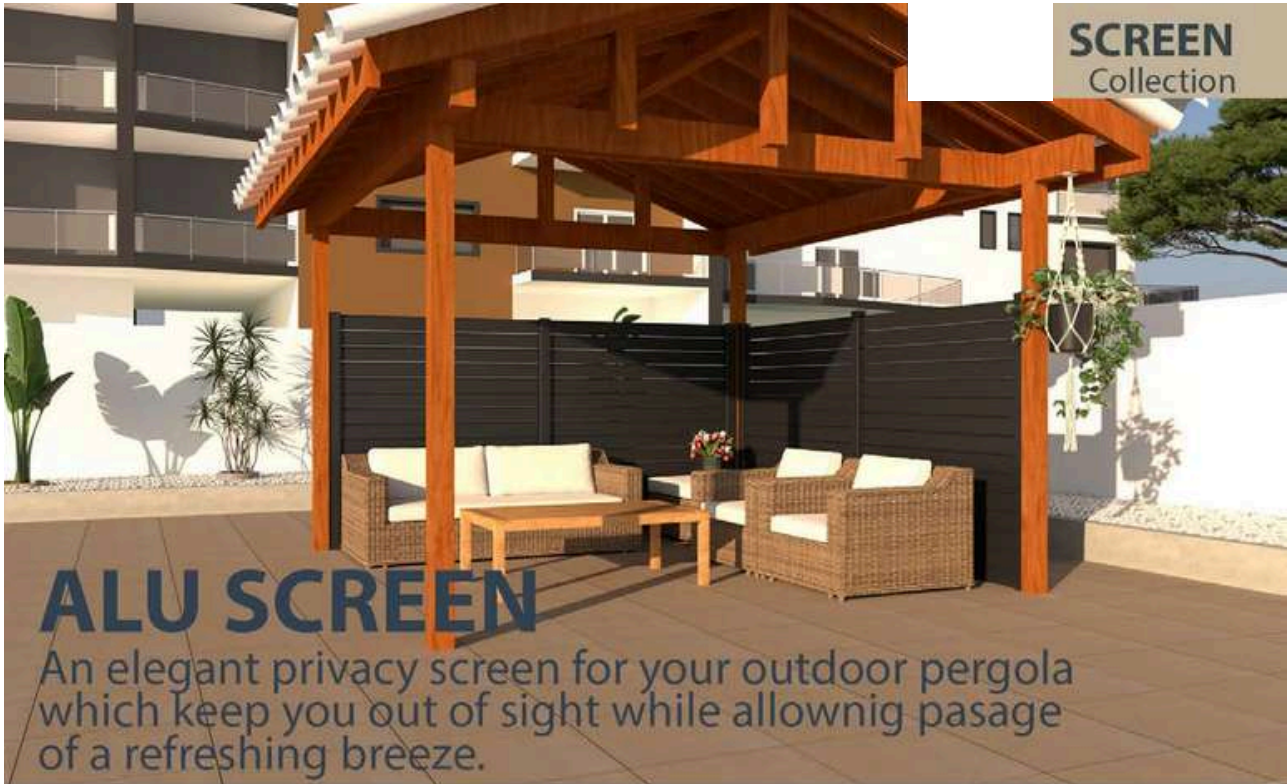



*Authorized distributor & installer*

**Corporate Office:**

7, Vrindavan Garden Society, Opp Jit Ground, Lokmanya Colony,  
off Paud Road, Kothrud. Pune-411038, Maharashtra, India.

[www.nirmalautomation.com](http://www.nirmalautomation.com)

Service:(+91) 92254 35222

Mail: [marketing@nirmalautomation.com](mailto:marketing@nirmalautomation.com)

**Follows Us:**



**For more details**

visit: [www.nirmalautomation.com](http://www.nirmalautomation.com)

